

Isometric
1 : 100

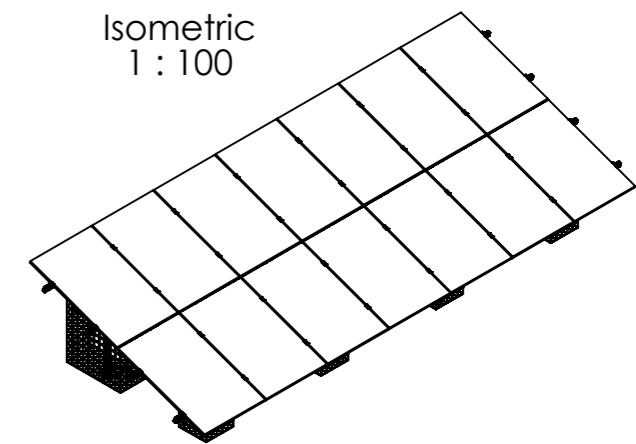

14 modules (2x7 Portrait)
for module width ≤ 1155 mm

12 modules (2x6 Portrait)
for module width 1155-1303 mm

Peak velocity $q_p[z]$: 0.67kN/m²
Ground snow load S_k : 1.75kN/m²



K2 Systems GmbH
Haldenstr. 1
71272 Renningen
Germany
+49 7159 42059-0

Designation: **Data sheet
N-Rack 2.20 Gabion 2x7 S**

Name	Date	Material:	Item no.:	A3
Designed C. Erb	26.01.2026	-	---	All dimensions in mm Sheet 1 of 1
Approved L. Kreemke	16.03.2026	Surface: -	Drawing no.: --	
Last change		Weight: -	Scale: 1:50	

This drawing is the sole property of K2 Systems GmbH. It is protected by copyright and may only be copied, reproduced or distributed to a third party with explicit permission!

Detail W
1 : 20

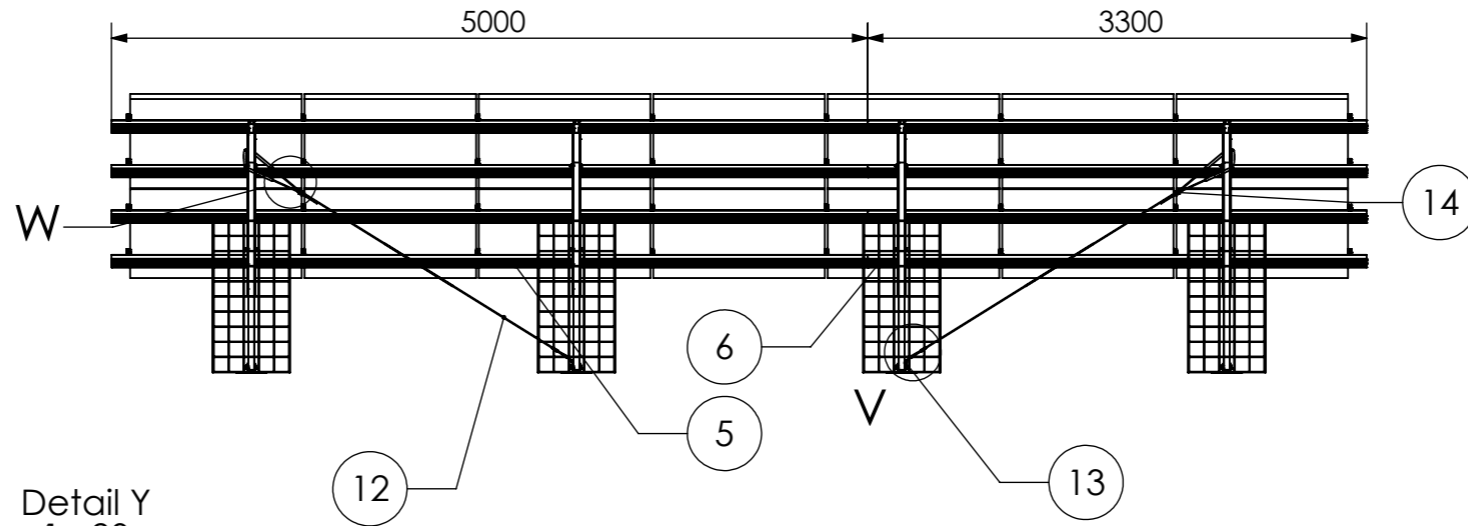
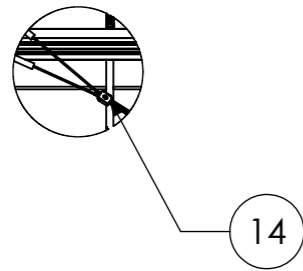

Detail V
1 : 10

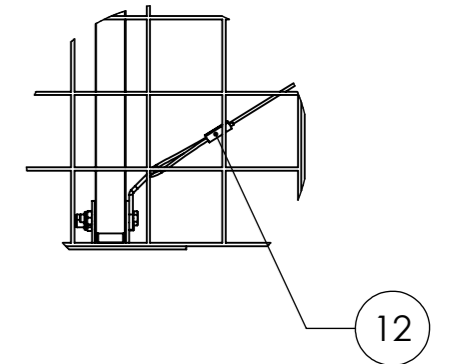

Detail Y
1 : 20

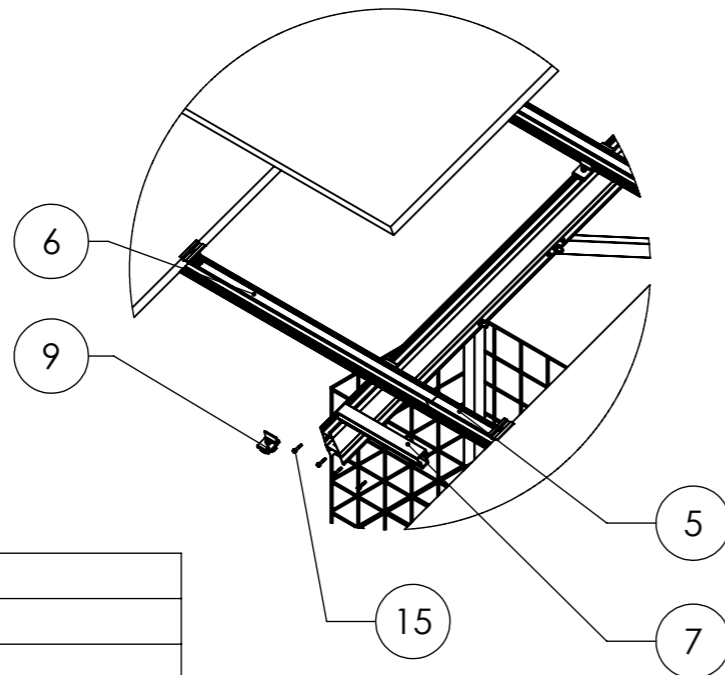

Detail Z
1:50

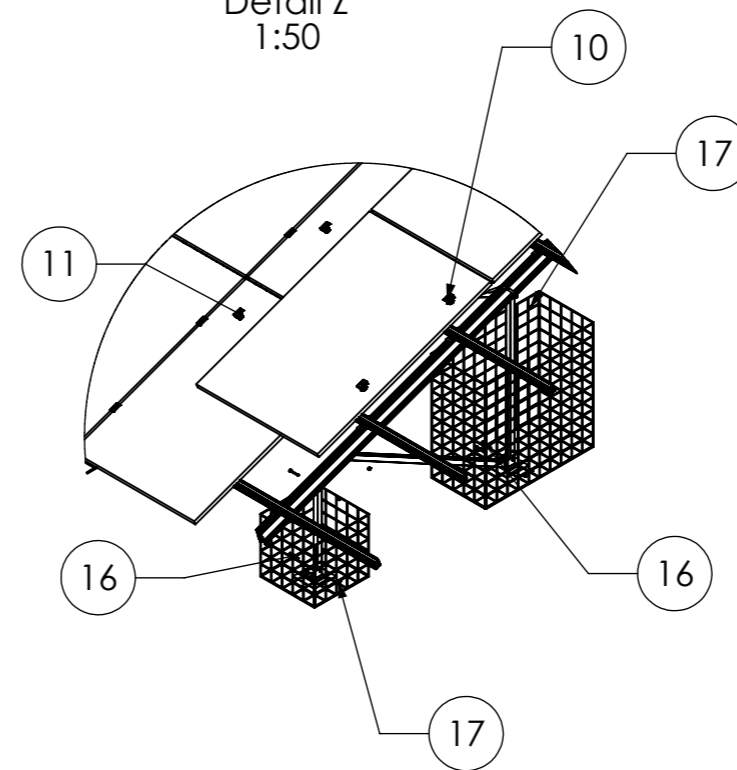

Isometric
1 : 100

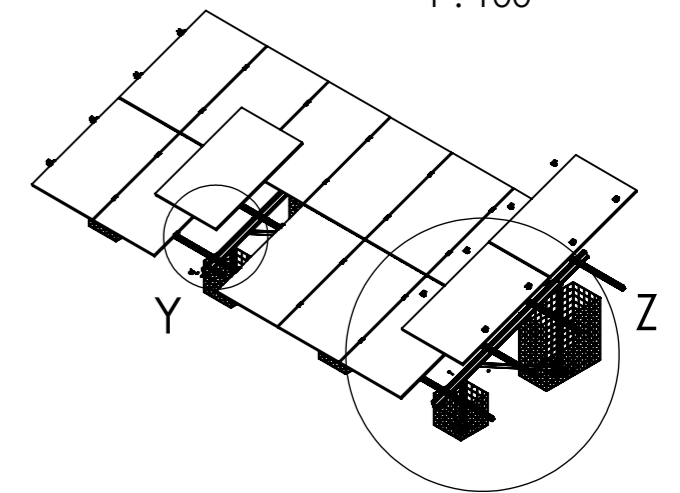

Pos.No.	Designation
1	Beam N-Rack 3020
2	3-Hole Brace N-Rack 715
3	3-Hole Brace N-Rack 1370
4	2-Hole Brace N-Rack 1696
5	CrossRail 73 - 5 m
6	CrossRail 73 - 3,3 m
7	CrossRail 73 Connector
8	N-Rack Base Plate
9	Climber 36/50 Set
10	EC Clamp Set
11	MC Clamp Set
12	Gripple Bracing
13	Gripple Angle
14	Gripple Lock
15	Self-tapping screw 5,5 x 25 - A2
16	Hexagon head bolt M10 x 70 ISO 4014 - A2-70
17	Hexagon nut M10 - DIN 985 - A2-70

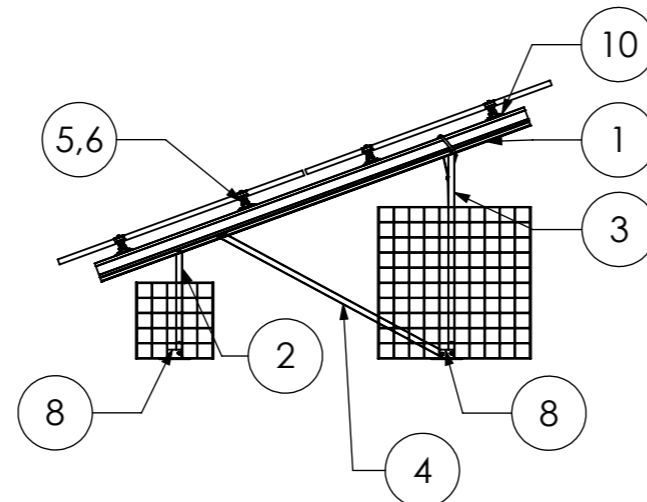

14 modules (2x7 Portrait)
for module width ≤ 1155 mm

12 modules (2x6 Portrait)
for module width 1155-1303 mm

Peak velocity $q_p[z]$: 0.67kN/m²
Ground snow load S_k : 1.75kN/m²



K2 Systems GmbH
Haldenstr. 1
71272 Renningen
Germany
+49 7159 42059-0

Designation: **Data sheet
N-Rack 2.20 Gabion 2x7 S**

Name	Date	Material:	Item no.:	A3
Designed C. Erb	26.01.2026	-	---	
Approved L. Kreemke	16.03.2026	Surface: -	Drawing no.: --	All dimensions in mm
Last change		Weight: -	Scale: 1:50	Sheet 1 of 1

This drawing is the sole property of K2 Systems GmbH. It is protected by copyright and may only be copied, reproduced or distributed to a third party with explicit permission!